



TECHNICAL DATA SHEET

DOOR ALL WEATHER M2

Ref. : AW.M2

1. DESCRIPTION

Intended use: For inside or outside environment.

Maximum dimensions : W 5.500 mm x H 5.500 mm.

Opening and closing speed: 1,2 m/s. Optionally different opening speed upon request. 2,4 m/s up to 15 m²; 2 m/s from 15 to 18 m²; 1,6 m/s from 18 to 23 m².

Operating type : gear driven, without ballast.

Frame made of structural channels (U) of 80 x 40 x 3 mm in steel, galvanised before cutting and folding or 80 x 40 x 2 mm, in stainless steel (option).

Drum in steel, diameter 102 x 2 mm, axis in steel. The drum is not visible : the door curtain always covers the drum, even when the door is in a closed position.

Reinforced side guides in polyethylene (PE-UHMW 1000); outer section 23 x 40 mm, on springs, reinforced.

Door curtain in reinforced PVC (900 g/m²), very resistant, in colour (RAL) yellow (1003), grey (7035), blue (5002), red (3000), green (6005), orange (2004), white (9010) or black (9005) and provided with lateral bearing strings (section 16 x 12,5 mm).

Motor without brake, with 4 poles, controlled by a frequency inverter. Power: 1,5 kW. Tension: 3 x 230 / 400 V. Protection degree IP 65.

Gearbox with worm and crownwheel, size 63 and reduction report 1/7.

Compact control panel in painted steel, with a circuit breaker, a padlockable divider, an adjustable timer for closing, a push button for opening and reset after a power failure or an emergency stop. Degree of protection: IP54.

The length of the electrical cables connecting the different electrical components such as the motor, the limit switches and other standard elements, allows the installation of the control box at about 1200 mm of the floor and 1000 mm of the door at the motorside.

Positioning limit switch: by means of an absolute encoder situated at the back of the motor.

Detectors delivered with the standard equipment :

A presence detector realised by means of an infrared photocell, installed at ± 20 mm of the axis of the curtain and detecting the presence of a pedestrian or a vehicle, immediately opens the door and keeps it open as long as the presence is detected. Position of the photocell : 300 mm from the floor.

Wireless DYNACO Detector (WDD) : a wireless detection system consisting of a transmitter in the bottom bag of the door and a receiver in the control box. The system operates according to the "open loop" principle: when the sensor encounters an obstacle, the transmitter leaves the standby mode and sends a signal to the receiver that immediately opens the door. The operating mode "open loop" offers an extremely high life time to the lithium battery of the transmitter, as it only operates when the sensor encounters an obstacle, otherwise, the transmitter remains inactive.

Power supply : single phase 220 to 240 V.

Frequency: 50-60 Hz. Fuses to be provided by the customer: 25 A.

2. EN 13241-1 CLASSIFICATION

Characteristics	Standard	Test acc.	Results
Water permeability	EN 12425	EN 12489	Class 3
Wind load	EN 12424	EN 12444	Class 4*
Wind permeability	EN 12426	EN 12427	Class 1
Safe openings	EN 12453	EN 12445	Pass
Mechanical resistance	EN 12604	EN 12605	Pass
Unintended movements	EN 12604	EN 12605	Pass
Thermal resistance	EN 12428	EN 12428	58,57W/m ² K
Performance (cycles)	EN 12604	EN 12605	1.000.000
* Indicated wind-load classification is for maximum dimension. For doors up to W5000mmxH5500: class 5			

3. REQUIRED SPACE :

All indicated dimensions are net: the space necessary for mounting and maintenance has to be provided. Reduced dimensions: upon request.

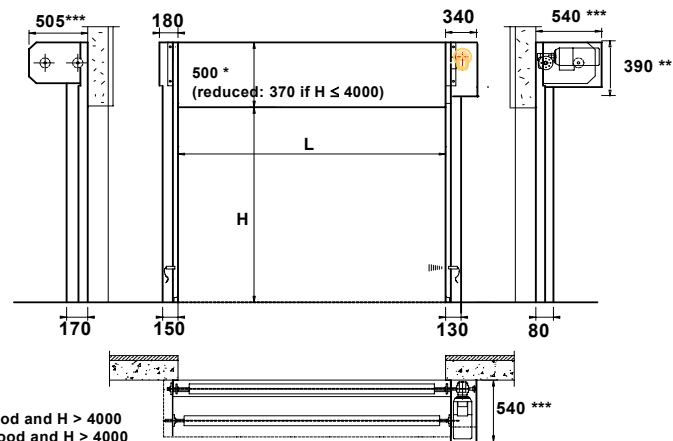

Remarks :

Within the framework of its policy of continuous development of its products, DYNACO preserves the right to modify the characteristics of its products and parts without prior notice. Special product orders are available upon request.